

MOGAS Watson Series™

Severe Service Valves



MOGAS®

Reliable and Robust

for Slurry and Corrosive Severe Services

MOGAS Watson Series™ bi-directional, metal-seated isolation valve is widely used in mining, chemical, petrochemical and refining industries. This ASME 150-600 Class valve is available in sizes from 1/2 to 12 inches, and in materials of construction and coatings to specifically combat the harsh environment of corrosion and erosion, and high pressures and temperatures.

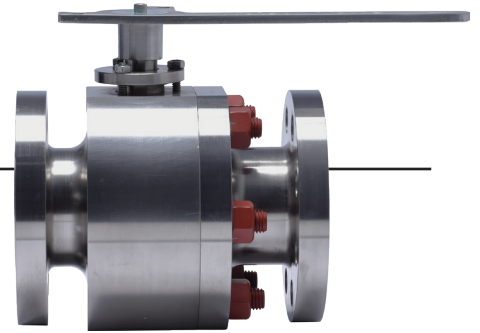

Designed to Last

Components in the MOGAS Watson Series™ valve are robustly engineered and manufactured from high quality alloys to combat severe service environments, such as acidic slurry and particulates that cause heavy solids build-up. The valves' ball and seats are precision mated lapped to provide the tightest seal possible, and are coated in-house using mechanically and metallurgically bonded coatings, which were developed over decades by metallurgical scientists.

Safety

Our valve is inherently safe to protect equipment, the environment and plant personnel. Safety enhancements include a large blowout-proof stem to accommodate high torques, and a configuration of graphite and Teflon sealing. All valves above 2-inch bore size are fire-test certified and compliant for oxygen services.

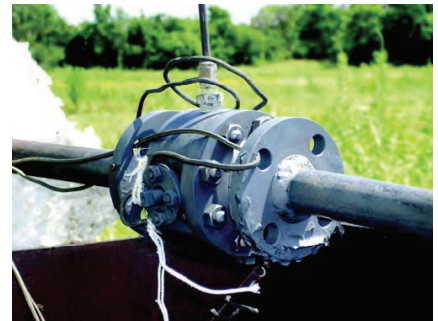

Service

When you select MOGAS products, service is a big part of what comes with them. And with the MOGAS Watson Series™ comes the same world-class after-sales service enjoyed by all MOGAS product lines. The MOGAS commitment to service means more than basic repairs. It also means timely access to our knowledgeable and experienced team of experts—anytime, anywhere in the world. And when our team becomes part of your team, you can trust that we will do everything we can to come through for you.



MOGAS Watson Series™ flanged ball valves are tested and certified to meet the fire test requirements of API 607.

When you have a problem, our technical advisors get to the root of it. They will look at your entire application to accurately identify and solve the issue. Using a comprehensive approach helps you improve equipment reliability and operational efficiency, as well as reduce costs.

Warranty

MOGAS offers a lifetime warranty on materials and workmanship. We stand behind our products for the life of the product.



MOGAS' dedicated cleanroom prepares valves for an oxygen-enriched environment.

Features and Benefits

MOGAS Watson Series™

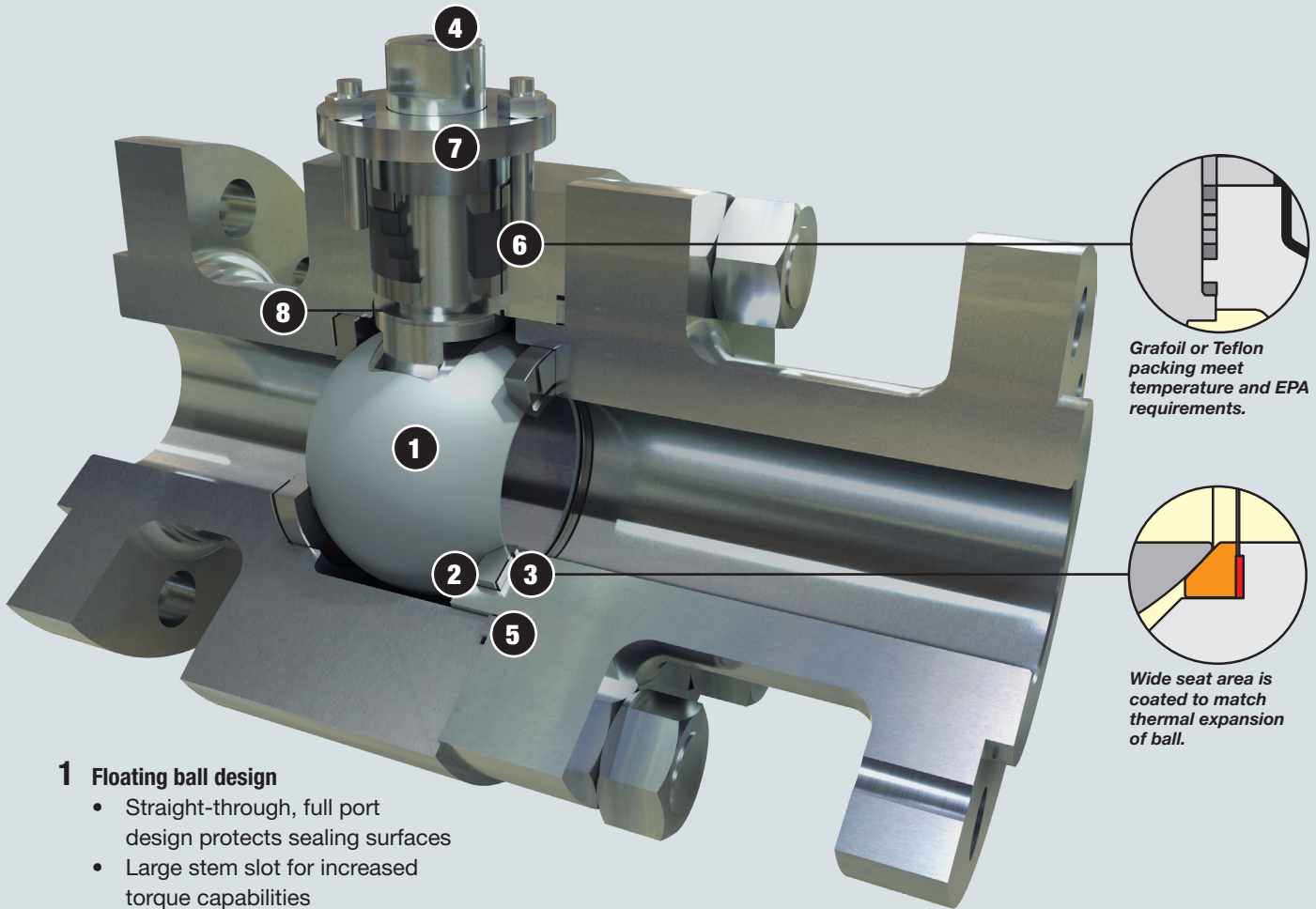

1 Floating ball design

- Straight-through, full port design protects sealing surfaces
- Large stem slot for increased torque capabilities

2 Seat

- Mate lapped to match the ball. Wide sealing surface supports high contact stress and resist wear on ball.

3 Seat ring

- Provides a positive backside seal and makes the valve totally bi-directional

4 Blowout-proof stem design

- Large drive tang to disburse loads preventing twisting and deformation
- Shank is big enough to handle 2X the torque requirement at standard pressures
- Ball tang is sized to handle large torque requirements and not twist

5 Body seal

- Uses controlled compression loads to maintain a bubble-tight seal between the body and end piece. The seal is a combination of the spiral-wound base metal with filler that can be either grafoil or Teflon™, depending on required service.

6 Packing box

- The configuration in graphite and Teflon provides sealing that has been emissions tested: less than 100 PPM for 15,000 cycles

7 Gland flange

- Self-centering and adjustable. Bolting arrangement provides an even loading of the packing.

8 Stem gasket

- Provides a smooth bearing surface to support the stems rotation

Features Not Shown

- Oxygen compliant in accordance with both end user mandate, as well as cleanroom industry standards
- Designed to standards: B16.34, ASME Section VIII
- Testing/qualification standards: MSS SP-61 or API 598 and fire safe API 607
- Coating technology based on application-specific operating conditions and materials of construction

Parts List

MOGAS Watson Series™

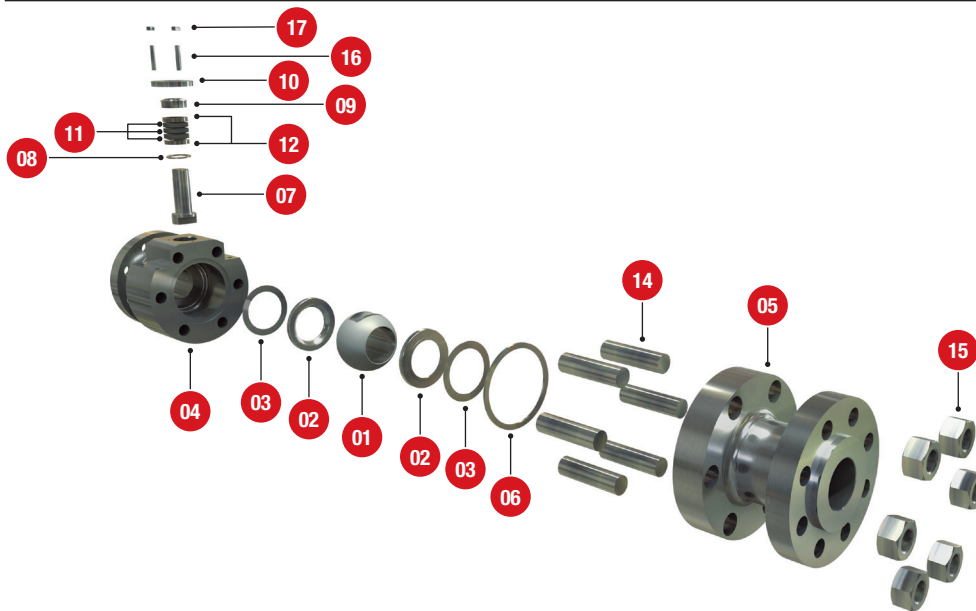

Valve Components	
No.	Description
01	Ball
02	Seat
03	Seat Ring
04	Body
05	End Connect
06	Seat Ring Seal, Graphite
07	Stem
08	Gasket, Spiral Wound Graphite
09	Thruster, Gland Flange
10	Gland Flange
11	Ring, Stem Packing ¹
12	Ring, Anti-Extrusion
14	Stud, Body
15	Nut, Body
16	Stud, Gland
17	Nut, Gland

¹ Quantity varies with valve size

Temperature vs Pressure — Standard Class Ratings							
Class	Material	Temperature, °F					
		-20 to 100	200	300	400	500	600
ASME 150 Maximum Pressure (psig)	A182-F51, -F53	290	260	230	200	170	140
	Alloy 20	290	260	230	200	170	140
	Ti Grade 12	288	260	230	200	170	140
	Monel 400	230	200	190	180	170	140
	A105	285	260	230	200	170	140
ASME 300 Maximum Pressure (psig)	A182-F51, -F53	750	745	665	615	580	555
	Alloy 20	750	740	710	680	655	605
	Ti Grade 12	750	701	609	536	490	463
	Monel 400	600	525	490	475	475	475
	A105	740	680	655	635	605	570
ASME 600 Maximum Pressure (psig)	A182-F51, -F53	1500	1490	1335	1230	1160	1115
	Alloy 20	1500	1485	1420	1365	1310	1210
	Ti Grade 12	1500	1401	1217	1071	979	926
	Monel 400	1200	1050	980	945	945	945
	A105	1480	1360	1310	1265	1205	1135
Class	Material	Temperature, °C					
		-29 to 38	100	150	200	250	300
ASME 150 Maximum Pressure (bar)	A182-F51, -F53	20.0	17.7	15.8	13.8	12.1	10.2
	Alloy 20	20.0	17.7	15.8	13.8	12.1	10.2
	Ti Grade 12	20.0	17.7	15.8	13.8	12.1	10.2
	Monel 400	15.9	13.8	12.9	12.5	12.1	10.2
	A105	19.6	17.7	15.8	13.8	12.1	10.2
ASME 300 Maximum Pressure (bar)	A182-F51, -F53	51.7	50.7	45.9	42.7	40.5	38.9
	Alloy 20	51.7	50.9	48.9	47.2	45.5	42.9
	Ti Grade 12	51.7	51.5	50.0	42.0	38.0	35.0
	Monel 400	41.4	35.9	33.7	32.7	32.6	32.6
	A105	51.1	46.6	45.1	43.8	41.9	39.8
ASME 600 Maximum Pressure (bar)	A182-F51, -F53	103.4	101.3	91.9	85.3	80.9	77.7
	Alloy 20	103.4	101.7	97.9	94.3	91.0	85.7
	Ti Grade 12	103.4	103.0	99.0	84.0	75.0	69.0
	Monel 400	82.7	71.9	67.5	65.4	65.2	65.2
	A105	102.1	93.2	90.2	87.6	83.9	79.6

Specifications

MOGAS Watson Series™

Dimensions (in)						
Size	Class	A	B	C	D	E
½	150	0.5	4.25	2.12	2.37	6
	300	0.5	5.50	2.62	2.18	6
	600	0.5	6.5	2.12	2.4	8
¾	150	0.75	4.62	2.31	2.18	6
	300	0.75	6	2.62	2.18	6
	600	0.75	7.5	2.3	2.5	8
1	150	1	5	2.5	3	7
	300	1	6.5	2.85	3	7
	600	1	8.5	3	3	10
1½	150	1.5	6.5	2.45	7.12	14
	300	1.5	7.5	3.25	7.6	13
	600	1.5	9.5	4.12	7.12	14
2	150	2	7	3.37	4.88	10
	300	2	8.5	3.46	4.88	10
	600	2	11.5	4.7	5	12
3	150	3	8	3.63	7.36	15
	300	3	11.13	4.95	7.36	15
	600	3	14	5.8	7.4	18
4	150	4	9	4.87	8.7	18
	300	4	12	5.03	8.7	18
	600	4	17	6.8	9.7	-
6	150	6	15.5	6.64	13.2	-
	300	6	15.87	7.13	13.2	-
	600	6	22	8.9	13.2	-
8	150	8	18	7.87	16.21	-
	300	8	19.75	8.76	16.21	-
	600	8	26	10.4	16.1	-
10	150	10	21	10.37	21.25	-
	300	10	22.38	10.75	21.25	-
	600	10	31	13.5	23.2	-
12	150	11.5	24	11.62	23	-
	300	11.5	25.5	12.32	23	-
	600	11.5	33	15	25	-

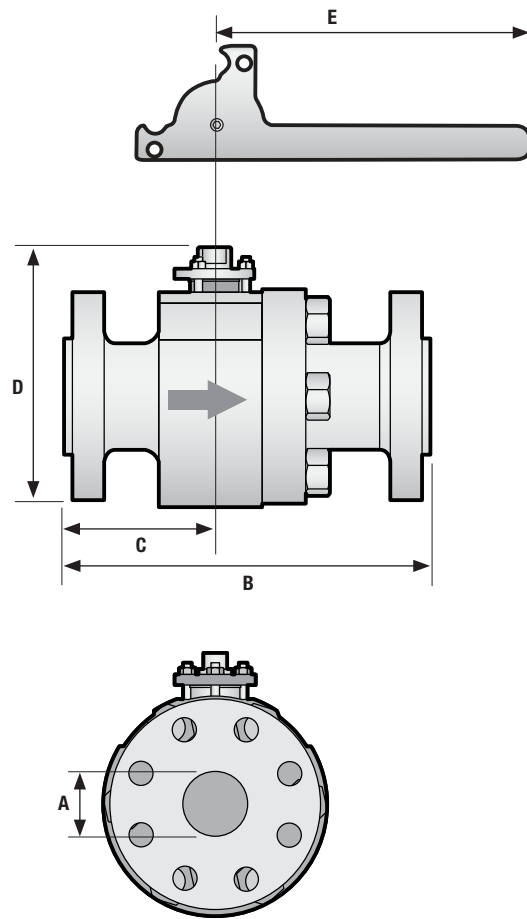

Severe Service

The MOGAS Definition

- Extreme temperatures
- High pressures
- Abrasive particulates
- Acidic products
- Heavy solids build-up
- Critical plant safety
- Large pressure differentials
- Velocity control
- Noise control

MOGAS Industries, Inc. **Headquarters**

14204 East Hardy Street
Houston, TX, USA 77039-1405
Phone: +1.281.449.0291
Fax: +1.281.590.3412
E-mail: mogas@mogas.com

Europe

Phone: +44 (0)116.279.3367

China

Phone: +86 (0)10.84549478

Australia

Phone: +61 (0)8.9456.3533

Middle East

Phone: +971 (0)4.880.8787

**For other MOGAS locations
or a distributor in your area,
visit us online at
www.mogas.com**